



**PETROL BLOWER**  
**RACPBB40**  
**USER GUIDE**

**CAUTION:** Read the instructions before using the machine!

# CONTENTS

1. INTENDED USE.....	3
2. SAFETY INSTRUCTIONS.....	3
3. YOUR PRODUCT.....	6
4. ASSEMBLY.....	8
5. FUELLING.....	8
6. OPERATION.....	9
7. MAINTENANCE AND STORAGE.....	11
8. DECLARATION OF CONFORMITY.....	12
9. WARRANTY.....	13
10. PRODUCT FAILURE.....	14
11. WARRANTY EXCLUSIONS.....	15

# 1. INTENDED USE

- This blower is meant to be used for blowing leaves, dust or garden debris into a desired direction. It must not be used for blowing water, chemical products, flammable material, metal or wood and other dangerous objects
- This product is intended for private domestic use only. It must be used outdoors.
- This product is not intended to be used in a closed room and places where exhausted gas and flames can be present.
- The use of this product in case of rain or humid environments is prohibited.
- Any other use might lead to damage of the appliance, property or personal injury.

# 2. SAFETY INSTRUCTIONS

## 2.1 GENERAL SAFETY RULES

**WARNING:** For your own safety, please read this manual before attempting to operate your new unit. Failure to follow instructions can result in serious personal injury. Spend a few moments to familiarize yourself with your blower before each use. If you give this tool to another person, also hand over this manual.

Use this tool as described in this manual. Any mishandling and any use contrary to the instructions will not in any way engage the liability of the manufacturer.

Non-compliance with safety instructions and use can cause a risk of electric shock, fire and /or injury to persons.

- Never allow children, handicapped or inexperienced people to use the machine. Local regulations may restrict the age of the user.
- Keep children, bystanders and animals away from the machine when using it (at least 15 meters).
- Remember that the user is responsible for accidents or damage to people or their property.
- Never dismantle the machine by yourself. Any disassembly or repair must be carried out by qualified personnel.
- Always wear personal protective equipment (PPE)
- Wear long, thick pants, boots, eye protection and safety gloves. Do not wear loose clothing, shorts or jewellery, and never work barefoot.
- To reduce the risk of injury, never wear loose clothing, scarf, collar, chain, etc. as they could get caught in moving parts. If you have long hair, be sure to tie it above shoulder level to prevent it from getting caught in the moving parts.
- The machine is extremely noisy and requires the use of good quality hearing protection every time you use it.
- Carry the machine only by its handle. Never try to wear it in other places.
- Refuel only in safe places. Open the tank slowly to release any pressure that may have built up in the tank. Clean any gasoline or spills from the machine before using it. To prevent any risk of fire, move at least 10 meters away from the refueling area before starting the machine.
- Switch off the machine before any preparation, installation or maintenance.
- All machine screws should be properly seated and tightened securely. The machine must be in good working order. Never use this machine if it is not assembled correctly.
- Keep handles clean and dry and free from gasoline or oil.
- Always store the machine in a clean and dry place away from all electrical equipment.
- Never start the engine in a closed or poorly ventilated room as the exhaust gases can be fatal.
- Only operate the machine at reasonable times - not too early in the morning or late at night, when

people may be disturbed.

- Never use the machine in bad weather or if there is a risk of lightning or thunderstorms. Do not use in the rain or in wet areas.
- Do not use this machine if you are tired, sick, under the influence of alcohol or drugs, or if you are taking medication.
- Do not use this machine in a poorly lit area.
- Keep a safe distance from moving parts and never touch surfaces that become hot during use.
- Wear a mask that filters out microscopic particles if your work generates dust, to avoid the risks associated with inhaling harmful dust.
- Before starting the machine, clear the area where you are going to use it. Remove stones, broken glass, nails, wire ropes, ropes or other objects that could be thrown or get caught in the machine.
- Always keep a good balance. Support yourself well on your legs and do not extend your arm too far. Otherwise, you could fall, slip or injure yourself.
- Let your machine cool down before putting it away.
- Before transporting this machine in a vehicle, empty the fuel tank and secure the machine so that it cannot move during transport.
- To reduce the risk of fire and burns, handle fuel with care. It is an extremely flammable substance.
- Do not smoke when handling fuel.
- Mix and store fuel in a container designed to hold gasoline.
- Mix the fuel in the open air, away from any sparks or flames.
- Choose a clean, bare surface, stop the engine, and allow it to cool before filling it.
- Slowly unscrew the fuel cap to relieve pressure and prevent fuel from spilling around the cap.
- Screw on the tank cap firmly after filling.
- Wipe down the machine if you have spilled fuel.
- Move at least 10m away from where you filled the fuel tank before starting the engine.
- Never attempt to burn spilled fuel.
- When replacing, use only replacement parts and accessories recommended by the manufacturer. Failure to do so could reduce the efficiency of your machine and put you at risk of injury.
- Maintain your machine with care, according to the instructions in the "Care & Cleaning" section of this manual.
- Check the condition of your machine before each use. Make sure that the fasteners are tight, that there are no fuel leaks and that no parts are damaged. Replace any damaged part.
- To reduce the risk of injury from contact with moving parts, stop the engine before installing or removing accessories.
- Do not use your machine if the protective elements are not installed. Always remove the spark plug before carrying out any maintenance or working on any moving part.
- Do not point the blower nozzle at people or pets.
- Never start this machine if the required accessories are not installed.
- Do not operate the machine near open windows,
- Use a rake and broom to loosen debris before blowing.
- Lightly dampen surfaces in dusty conditions before working.
- Use the pipes fully assembled so that the air flow can reach the floor.
- Caution: there is a risk of danger from rotating parts. Avoid coming into contact with them.
- In case of blockage or breakdown, stop using the machine immediately. Inspect it and remove the blockage securely (see chapter "Maintenance"). In the event of a fault, please take your machine to a qualified service for inspection.

## 2.2 MAINTENANCE AND STORAGE

When the machine is stopped for servicing, inspection, or storage, or to change an accessory, shut off the power source and make sure that all moving parts have come to a complete stop. Allow the machine to cool before making any inspections, adjustments, etc. Maintain the machine with care and keep it clean.





- Store the machine in a dry place out of the reach of children.
- Always allow the machine to cool before storing.
- Replace worn or damaged parts for safety. Use only genuine replacement parts and accessories.
- Never attempt to override the interlocked feature of the guard.





## 2.3 RESIDUALS RISKS

Even if you use this product in compliance with all safety requirements, potential risks of injury and damage remain. The following hazards may arise from the structure and design of this product. Always be vigilant when using this product, so you can recognize and manage the risks early. Rapid intervention can prevent serious injury and property damage. Turn off the tool if there are any malfunctions. Have it checked by a qualified professional and have repairs carried out, if necessary, before using it again.

- There are harmful health consequences resulting from the emission of vibrations if the product is used for long periods of time or not properly managed and properly maintained.
- There is risk of injury and property damage due to attachments or broken the sudden impact of hidden objects.
- Risk of injury to persons and property caused by flying objects.
- Inhalation of gasoline particles or toxic gases.
- Contact with moving parts. (Ex: Danger related to the starter handle (Risk of kickback))
- Hearing loss if hearing protection is not worn.

## 2.4 SYMBOLS

	Read instruction handbook.
	Risk of projection, keep bystanders away.
	Wear ocular protection and hearing protection.
	Guarantee sound power level.

	Risk of fire.
	Hot surface.
	Risk of inhalation of exhausted gas.
	Pull the pull start with the choke in this position, when you pull out the choke, the air flap closed, when you push in the choke, the air flap opened.

## 3. YOUR PRODUCT

### 3.1 DESCRIPTION

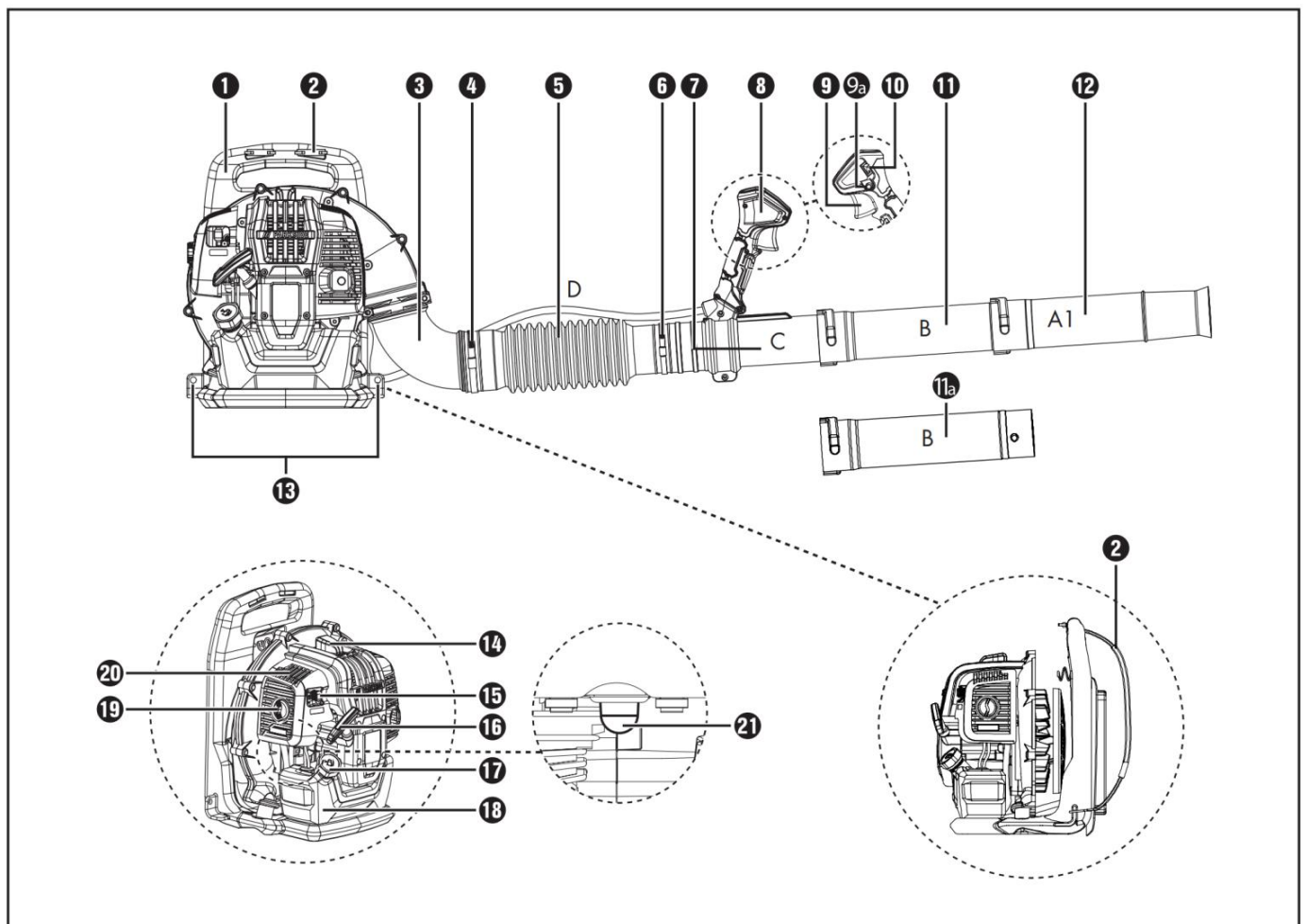

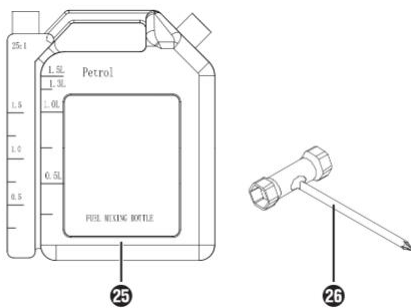
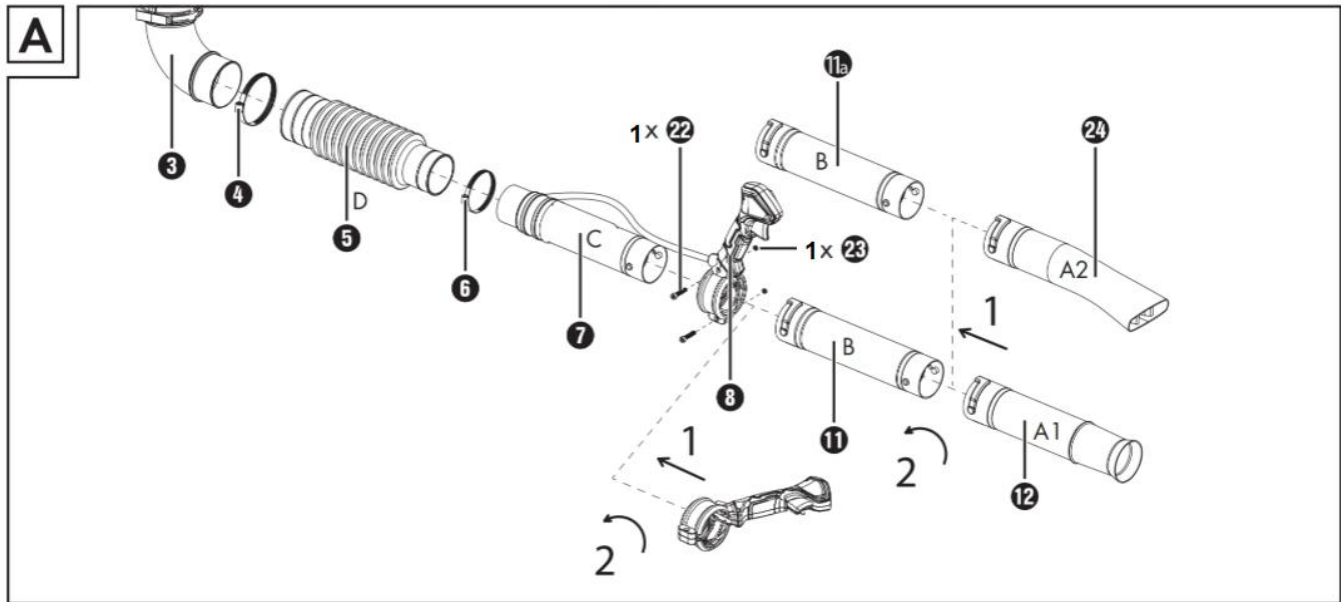

- |                          |   |
|--------------------------|---|
| 1. Frame                 | 13. Attachment hole (for the carrying strap)      |
| 1a. Carrying handle      | 14. Spark plug connector                          |
| 2. Carrying strap        | 15. Choke   |
| 3. Curved pipe           | 16. Pull start                                    |
| 4. Hose clip             | 17. Fuel tank cap                                 |
| 5. Flexible pipe (D)     | 18. Fuel tank                                     |
| 6. Hose clip             | 19. Locking screw (for the air filter cover)      |
| 7. Control pipe (C)      | 20. Air filter cover                              |
| 8. Operating lever       | 21. Fuel pump (primer)                            |
| 9. Throttle              | 22. 1x fastening screws (for the operating lever) |
| 9a. Throttle lock        | 23. 1x locking nuts (for the operating lever)     |
| 10. On/Off switch        | 24. End pipe, flat (A2)                           |
| 11. Pipe extension (B)   | 25. Mixing tank                                   |
| 11a. Pipe extension (B)  | 26. Spark plug wrench/flat-head screwdriver       |
| 12. End pipe, round (A1) |   |

### 3.2 TECHNICAL SPECIFICATIONS

Model	RACPBB40
Power	1,20 kW /7000min <sup>-1</sup>
Displacement	43 cm <sup>3</sup>
Max speed	7500/min
Air volume	900m <sup>3</sup> /h
Air speed	223km/h

Net Weigh	Max. 7.9kg
Measured sound pressure level	96.2dB (A) K = 3 dB (A)
Measured sound power level measured	108.2 dB (A) K = 3 dB (A)
Guarantee sound power level	112 dB(A)
Vibration value	4.021m/s <sup>2</sup> K = 1,5 m/s <sup>2</sup>

## 4. ASSEMBLY

(See fig. A)

- 1) Take the two hose clips (4) + (6) and slide them over the ends of the flexible pipe (5).
- 2) Push the larger end of the flexible pipe (5) onto the curved pipe (3) and tighten the hose clip (4) using the flat-head screwdriver (26) .
- 3) Slide the control pipe (7) into the flexible pipe section (5) and tighten the hose clip (6) using the flat-head screwdriver (26).
- 4) First loosen the fixing screws (22) on the operating lever (8).
- 5) Slide the operating lever (8) onto the guide of the head pipe (7).
- 6) Attach the operating lever (8) using the supplied fastening screws (22) and locking nuts (23) .
- 7) Push the pipe extension (11) onto the control pipe (7).
- 8) To fix the pipe extension (11a) in place, turn it clockwise (see fig. A) and secure it by tightening the inserted screw.
- 9) If an extension is required, push the second pipe extension (11a) onto the previously mounted pipe extension (11).
- 10) To fix the pipe extension (11a) in place, turn it clockwise (see fig. A) and secure it by tightening the inserted screw.
- 11) Push the desired end pipe (round) (12) or end pipe (flat)(24) onto the pipe extension(11) or (11a) and fix it in place by turning it clockwise (see Fig. A) and secure it by tightening the inserted screw

## 5. FUELLING

### Fuel

Use a mixture of unleaded gasoline and 2-stroke engine oil for best results.

**WARNING:** Do not pour gasoline directly into the machine. This will cause irreversible damage to the engine and will void the warranty. Do not use a fuel mixture that has been stored for more than 90 days.

### Oil / fuel mixture

First put oil in an approved container. Then add gasoline, and shake the container to get a full mix. The oil / fuel ratio must be 40: 1

### Refueling

Open the fuel tank by removing its cap. Gently pour the fuel. Wipe off any overflow. Then close the tank.

### Precautions for fuelling

- Always use extreme care when handling fuel! Fuel is highly flammable.
- Never attempt to fuel the blower if the fuel system components are damaged or are leaking.
- Never attempt to refuel the engine while it is running or still warm, allow it to cool before fuelling.
- Never smoke or light any fires near the blower or fuels.
- Always transport and store fuels in an approved container.
- Never place flammable material close to the engine muffler.



- Never operate the blower without a properly functioning muffler and spark arrestor installed.
- Never operate the blower unless it is properly assembled and in good working condition.
- Do not use petrol which contains ethanol or methanol as it may damage the fuel lines and other engine parts.
- Mix only enough fuel for your immediate needs. If fuel must be stored longer than 30 days, it should first be treated with a stabilizer or similar product.

## 6. OPERATION

### CAUTION!

Please comply with the statutory provisions in the relevant noise protection regulations.

Before starting the appliance, always check that:

- The fuel system is not leaking.
- All screw connections are firmly seated.

### 6.1 STARTING WHEN THE ENGINE IS COLD

#### ATTENTION!

Never allow the pull start (16) to whip back. This could cause damage.

- Set the On/Off switch (10) to "I".
- Press the throttle (9) halfway down and then push down the throttle lock(9a)
- Now release the throttle (9) and the throttle lock (9a) . The throttle (9) is now locked.
- Pull the choke (15) out.
- Press the fuel pump (primer) (21) 6x.
- Press the appliance against the floor with your left hand on the frame (1) (ATTENTION! Do not use your foot!). With your right hand on the pull start (16), pull it slowly until you feel resistance.

#### ATTENTION!

Always pull the pull start (16) straight out. Hold the handle of the pull start (16) firmly when the pull start (16) retracts. Do not allow the pull start (16) to whip back.

- Now pull the pull start (16) quickly so that the engine starts. If the engine does not start, repeat the process.
- When the engine starts, press down the throttle (9). The choke will be reset.

If the engine does not start after several attempts, read the "Troubleshooting" section.

**NOTE:** At high outdoor temperatures it is possible that even a cold engine has to be started without using the choke (15)!

### 6.2 TARTING WHEN THE ENGINE IS HOT

(The appliance has been turned off for less than 15—20 minutes)

- Set the On/Off switch (10) to "I".
- The choke (15) does not need to be pulled out to start a warm motor.
- Press the appliance against the floor with your left hand on the frame (1) (ATTENTION! Do not use your foot!). With your right hand on the pull start (16), pull it slowly until you feel resistance.

 **ATTENTION!** Always pull the pull start (16) straight out. Hold the handle of the pull start (16) firmly when the pull start (16) retracts. Do not allow the pull start (16) to whip back.

Now pull quickly on the pull start (16). The appliance should start after 1-2 pulls. If the appliance has still not started after 6 pulls, repeat the process as described in “Starting when the engine is cold”.

### 6.3 PARKING THROTTLE/THROTTLE LEVER LOCK

- Press the throttle (9) halfway down and then push down the throttle lock (9a).
- Now release the throttle (9) and the throttle lock (9a). The throttle (9) is now locked.

**NOTE:** When the throttle lever (9a) lock is actuated, the unit does not run in full throttle position!

### 6.4 TURNING THE ENGINE OFF

Emergency stop sequence

If the appliance needs to be stopped immediately, turn the On/off switch (10) to ‘O’.

Normal sequence

Release the throttle (9). The engine idles. Then move the On/Off switch (10) to “O”.

### 6.5 BLOWER OPERATIONS

1. Use the blower for trees, shrubs, flower beds, and hard-to-clean areas.
2. Use the unit around buildings and for other normal cleaning procedures.
3. Use the blower around walls, overhangs, fences, and screens.



**WARNING:** Before using your blower, reread the safety instructions provided in this manual as well as the device's manual. These precautions and instructions are necessary for your protection.



**WARNING:** To prevent flying debris, always wear safety glasses or a face shield when operating the blower.



**WARNING:** The operator must keep a minimum distance of 15m from other people in the work area.

4. We recommend that a face mask be worn when operating the blower in dusty areas.
5. Stand away from the debris, at a distance that will easily allow you to control the direction of blown debris. Never blow debris in direction of bystanders.
6. To control velocity of air stream, blower can be operated at any speed between idle and full throttle.  
Experience with the unit will help you determine the amount of airflow necessary for each application.
7. To reduce sound levels, limit the number of pieces of equipment used at any one time.
8. Check your equipment before operation, especially the muffler, air intakes and air filters.
9. Use rakes and brooms to loosen debris before blowing. In dusty conditions, slightly dampen surfaces when water is available.
10. Conserve water by using power blowers instead of hoses for many lawn and garden applications, including areas such as gutters, screens, patios, grills, porches and gardens.
11. Use intermediate tube plus nozzle of your choice so the air stream can work close to the ground.
12. After using blowers and other equipment, CLEAN UP! Dispose of debris in trash receptacles.

### 6.6 OPERATING INSTRUCTIONS

1. Follow the instructions “STARTING A COLD ENGINE”.
2. Once unit is running, place unit on your back by slipping arms through the shoulder straps as if you were putting on a backpack.
3. When preparing to clear an area of debris, always position yourself so that you can control the direction

debris will be blown.

4. The control handle and the flexibility of the blower tube assembly will allow you to clear the most hard-to-reach areas.
5. The hand grip, throttle trigger, lock-out button and on/off ignition switch are all mounted on a swivel handle that offers a wide range of operating positions and comfort.

## 7. MAINTENANCE AND STORAGE

### Cleaning the Air Filter

Dirty air filters reduce engine power increase fuel consumption and make starting more difficult.

- Release the screws and pull off the filter cover.
- Remove the filter from the cover and inspect it - if it is dirty or damaged, clean the filter or fit a new one.
- Install the main filter and prefilter elements in the filter cover.
- Fit the cover on the filter base and tighten it down firmly.

### Carburetor general information

Your carburetor comes from the factory with a standard setting.

This setting provides an optimum fuel-air mixture under most operating conditions. The high-speed screw alters the engine's power output and the maximum off-load engine speed.

If the setting is too lean there is a risk of engine damage due to insufficient lubrication and overheating.

A modification of the carburetor adjustment must be made by a qualified after-sales service.



### Checking the Spark Plug

If engine is down on power, difficult to start or runs poorly at idle speed first check the spark plug.

- Remove the spark plug - see "Starting / Stopping the Engine"
- Check electrode gap (A) and readjust if necessary – see "Specifications".



### Storing the Machine

#### For periods of about 3 months or longer:

- Drain and clean the fuel tank in a well-ventilated area.
- Run engine until carburetor is dry - this helps prevent carburetor diaphragms sticking together.
- Thoroughly clean the machine- pay special attention to the cylinder fins and air filter.
- Store the machine in a dry, high or locked location - out of the reach of children and other unauthorized persons.
- Do not expose the container to direct sunlight for unnecessarily long periods. UV rays can make the container material brittle, which could result in leaks or breakage.

## 8. DECLARATION OF CONFORMITY



BUILDER SAS

ZI, 32 rue Aristide Bergès – 31270 Cugnaux - France

Tel: +33 (0)5.34.502.502 Fax: +33 (0)5.34.502.503

Declares that the machines:

PETROL BLOWER

Model: RACPBB40

Serial No.: **20220506251-20220507750**

The people name holding the technical file: M. Olivier Patriarca

Have been designed in compliance with the following standards:

EN15503: 2009/A2:2015

EN ISO14982: 2009

And in accordance with the following directives:

Directive Machine 2006/42/EC

EMC directive 2014/30/EU

Emission directive (EU) 2016/1628 & 2018/989/EU

Noise directive 2000/14/CE Annexe V & Directive 2005/88/CE

Measured sound power level measured	108.2 dB (A) K = 3 dB (A)
Guarantee sound power level	112 dB(A)

Cugnaux, 15/02/2022

Philippe MARIE / PDG

## 9. WARRANTY



### WARRANTY

The manufacturer guarantees the product against defects in material and workmanship for a period of 2 years from the date of the original purchase. The warranty only applies if the product is for household use. The warranty does not cover breakdowns due to normal wear and tear.

The manufacturer agrees to replace parts identified as defective by the designated distributor. The manufacturer does not accept responsibility for the replacement of the machine, in whole or in part, and/or ensuing damage.

**The warranty does not cover breakdowns due to:**

- insufficient maintenance.
- abnormal assembly, adjustment or operations of the product.
- parts subject to normal wear and tear.

**The warranty does not extend to:**

- shipping and packaging costs.
- using the tool for a purpose other than that for which it was designed.
- the use and maintenance of the machine done in a manner not described in the user manual.

Due to our policy of continuous product improvement, we reserve the right to alter or change specifications without notice. Consequently, the product may be different from the information contained therein, but a modification will be undertaken without notice if it is recognized as an improvement of the preceding characteristic.

**READ THE MANUAL CAREFULLY BEFORE USING THE MACHINE.**

When ordering spare parts, please indicate the part number or code, you can find this in the spare parts list in this manual. Keep the purchase receipt; without it, the warranty is invalid. To help you with your product, we invite you to contact us by phone or via our website:

- **+33 (0)9.70.75.30.30**
- **<https://services.swap-europe.com/contact>**

You must create a "ticket" via the web platform.

- Register or create your account.
- Indicate the reference of the tool.
- Choose the subject of your request.
- Describe your problem.
- Attach these files: invoice or sales receipt, photo of the identification plate (serial number), photo of the part you need (for example: pins on the transformer plug which are broken).



# 10. PRODUCT FAILURE

## WHAT TO DO IF MY MACHINE BREAKS DOWN?

### **If you bought your product in a store:**

- a) Empty the fuel tank if your product has one.
- b) Make sure that your machine is complete with all accessories supplied, and clean! If this is not the case, the repairer will refuse the machine.

Go to the store with the complete machine and with the receipt or invoice.

### **If you bought your product on a website:**

- a) Empty the fuel tank if your product has one.
- b) Make sure that your machine is complete with all accessories supplied, and clean! If this is not the case, the repairer will refuse the machine.
- c) Create a SWAP-Europe service ticket on the site: <https://services.swap-europe.com> When making the request on SWAP-Europe, you must attach the invoice and the photo of the nameplate (serial number).
- d) Contact the repair station to make sure it is available before dropping off the machine.

Go to the repair station with the complete machine packed, accompanied by the purchase invoice and the station support sheet downloadable after the service request is completed on the SWAP-Europe site

For machines with engine failure from manufacturers BRIGGS & STRATTON, HONDA and RATO, please refer to the following instructions.

Repairs will be done by approved engine manufacturers of these manufacturers, see their site:

- <http://www.briggsandstratton.com/eu/fr>
- <http://www.honda-engines-eu.com/fr/service-network-page;jsessionid=5EE8456CF39CD572AA2AEEDFD290CDAE>
- <https://www.rato-europe.com/it/service-network>

**Please keep your original packaging to allow for after-sales service returns or pack your machine with a similar cardboard box of the same dimensions.**

**For any question concerning our after-sales service you can make a request on our website <https://services.swap-europe.com>**

**Our hotline remains available at +33 (9) 70 75 30 30.**



# 11. WARRANTY EXCLUSIONS

## THE WARRANTY DOES NOT COVER:

- Start-up and setting up of the product.
- Damage resulting from normal wear and tear of the product.
- Damage resulting from improper use of the product.
- Damage resulting from assembly or start-up not in accordance with the user manual.
- Breakdowns related to carburetion beyond 90 days and fouling of carburetors.
- Periodic and standard maintenance events.
- Actions of modification and dismantling that directly void the warranty.
- Products whose original authentication marking (brand, serial number) has been degraded, altered or withdrawn.
- Replacement of consumables.
- The use of non-original parts.
- Breakage of parts following impacts or projections.
- Accessories breakdowns.
- Defects and their consequences linked to any external cause.
- Loss of components and loss due to insufficient screwing.
- Cutting components and any damage related to the loosening of parts.
- Overload or overheating.
- Poor power supply quality: faulty voltage, voltage error, etc.
- Damages resulting from the deprivation of enjoyment of the product during the time necessary for repairs and more generally the costs related to the immobilization of the product.
- The costs of a second opinion established by a third party following an estimate by a SWAP-Europe repair station
- The use of a product which would show a defect or a breakage which was not the subject of an immediate report and/or repair with the services of SWAP-Europe.
- Deterioration linked to transport and storage\*.
- Launchers beyond 90 days.
- Oil, petrol, grease.
- Damages related to the use of non-compliant fuels or lubricants.

\* In accordance with transport legislation, damage related to transport must be declared to carriers within 48 hours maximum after observation by registered letter with acknowledgement of receipt.

This document is a supplement to your notice, a non-exhaustive list.

**Attention:** all orders must be checked in the presence of the delivery person. In case of refusal by the delivery person, it you must simply refuse the delivery and notify your refusal.

**Reminder:** the reserves do not exclude the notification by registered letter with acknowledgement within 72 hours.

**Information:** Thermal devices must be wintered each season (service available on the SWAP-Europe site). Batteries must be charged before being stored.



BUILDER SAS  
32, rue Aristide Bergès - ZI 31270 Cugnaux – France  
Made in PRC 2022